

**NESH MARKETING SDN BHD**

(199301002028)

12, Jalan Puteri 4/2, Bandar Puteri, 47100 Puchong, Selangor, Malaysia.

Tel: 03-8060 3668

E-mail: [info@nesh.com.my](mailto:info@nesh.com.my) Website: [www.nesh.com.my](http://www.nesh.com.my)

Facebook: NESH Malaysia Instagram: neshmalaysia



# HeroVac

## User Manual

Model: VC2025

Please read this user manual carefully before usage. Kindly retain for future reference.

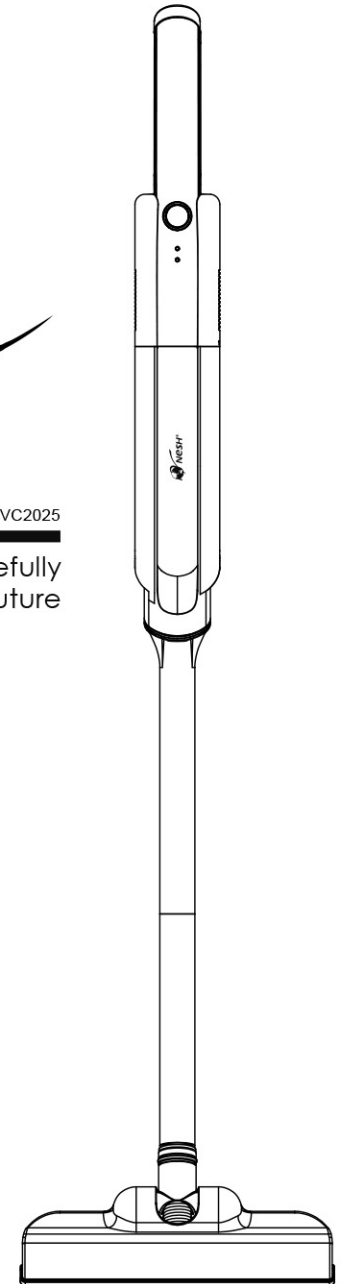

# Contents

Dear NESH Valued Customer:

Thank you for choosing our product. Kindly read this user manual carefully for safe and effective use of the product. Please keep this manual at safe place for future reference. Remember to include this user manual should you send this product to your friend as a gift. We hope you like our product.

Product Specification	.....01
Product Structure	.....02
Safety Precautions	.....04
Parts Installation	.....05
Product Usage	.....06
Cleaning & Maintenance	.....08
Troubleshooting	.....09
Limited Warranty	.....10
Terms & Conditions	.....10

### Disclaimer:

The contents of this user manual have been carefully checked. The company reserves the right to explain for any mistake and/or omission in print or misunderstanding of the contents. In addition, any technical improvement will be updated in the revised version without prior notice. With a view to constantly improving our products, we reserve the right to make any changes in their technical, program or aesthetic features connected with their technical evolution.

### Product Specification

Model	: VC2025
Weight	: 1.8kg
Working Voltage	: 11.1V
Rated Power	: 90W
Battery Capacity	: 2500mAh

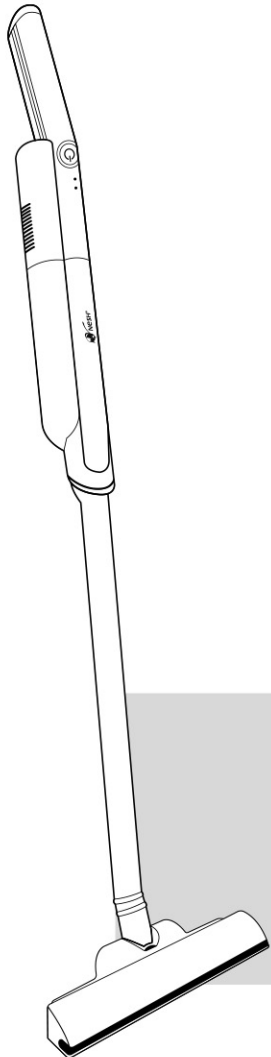

# Product Structure

## Product Features

This is a versatile cordless vacuum cleaner for whole house cleaning, which can be easily converted into a light-weight handheld vacuum cleaner with one-touch. You can even use it as portable car vacuuming.

- Sleek and Space-saving Design
- Brushless Motor for Efficient Suction
- Dual Filtration System with HEPA Filter
- Cyclone Technology
- Detachable Battery Pack
- Powerful 2-Speed Suction

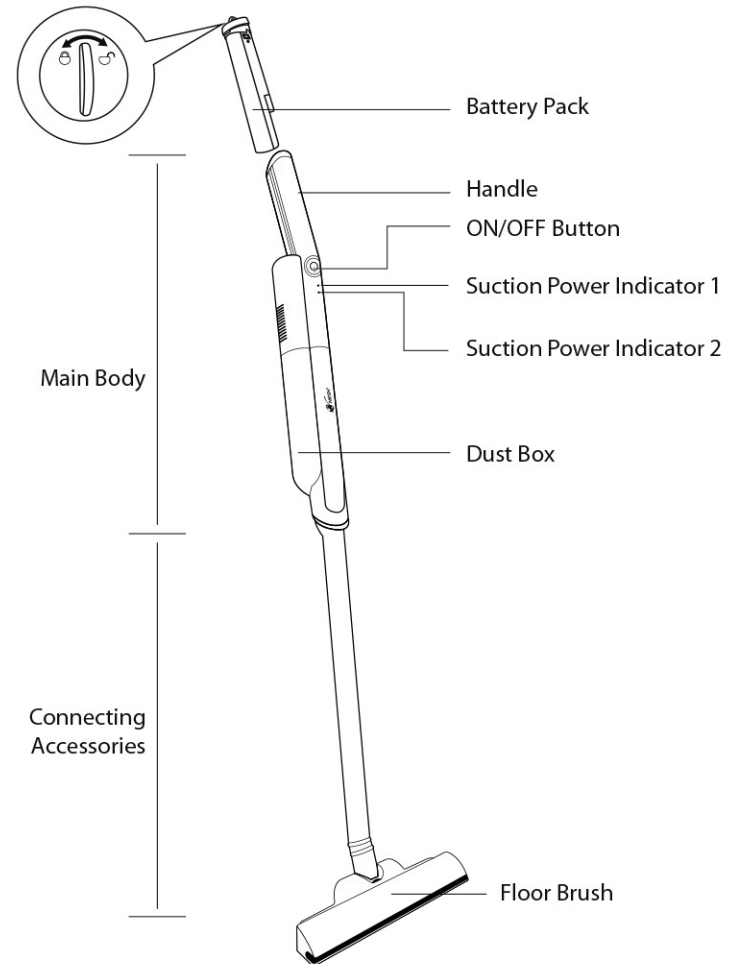

## Product Structure

### Packing List

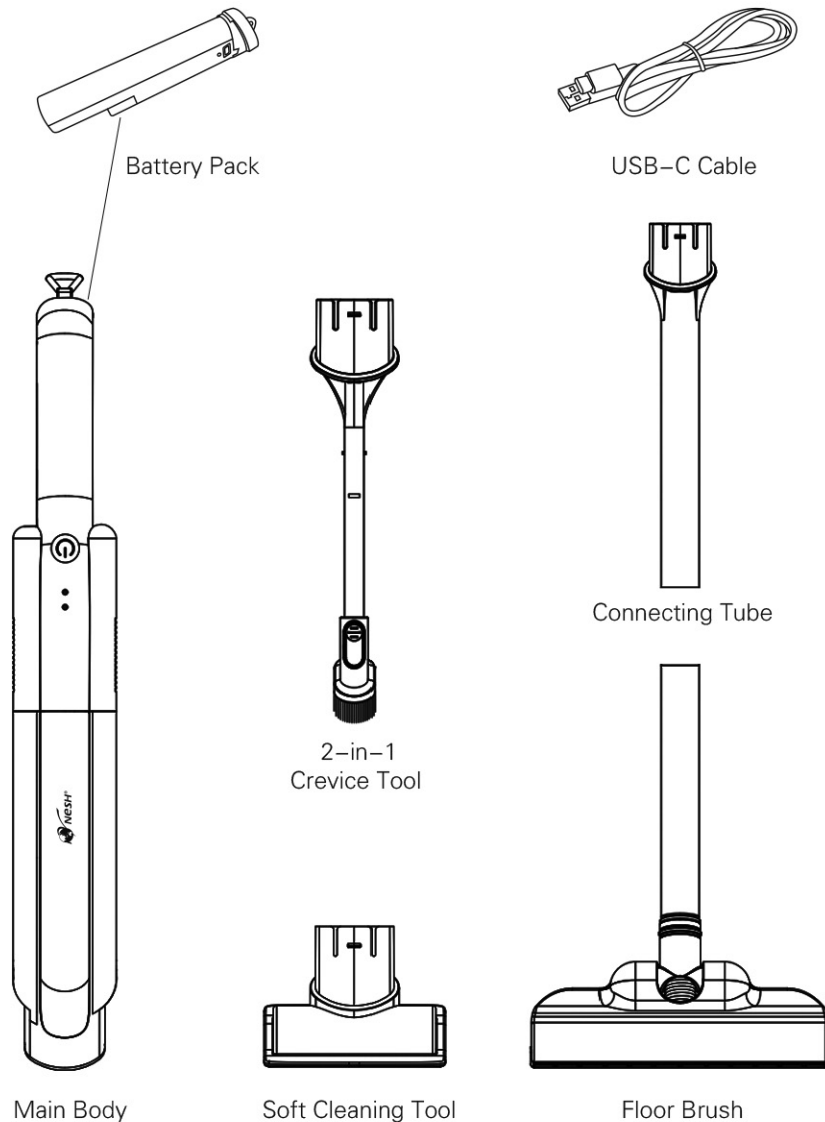

Illustrations shown on this manual are for reference only and actual product prevails.

## Safety Precautions

- Check all parts for damage before each use. Discontinue if found damage.
- Use only genuine parts.
- Use the product for its intended purpose only.
- Do not contact any parts with liquid except filters and dust box.
- Keep the product out of reach of children.
- Supervision shall be given to person with disability when operating this product.
- Always turn off the product before connecting or disconnecting power.
- Do not touch the power plug with wet hands.
- Make sure dust box, filters and connected parts are in place before use.
- Always keep the ventilated outlets clear and unblocked.
- Do not use the product if the airflow is improper.
- Keep the suction parts away from body and loose clothing.
- Do not use the product if it's malfunction, damage or has been submerged in water.
- Pay attention when cleaning the staircase.
- Do not leave the product unattended when power on.
- When vacuuming the carpet, do not stop at one spot to avoid damaging the carpet fibre.
- Do not place the product on unstable surfaces such as chairs or tables.
- Turn off the product before plugging or unplugging the USB-C cable / battery pack.
- Turn off the product before adjustment, using, cleaning, maintenance or troubleshooting.
- Air-dry the filter completely before use to prevent damage.
- Do not attempt to modify or repair the product.
- Make sure the product is at room temperature before operating.

### Battery Pack

The battery pack is the power source for the product, handle with care and follow instructions.

- To prevent accidental hazards, make sure the product is turned off before carrying it. Do not carry it with finger on the ON/OFF button.
- Keep the battery away from metal objects to prevent short-circuits.
- Do not attempt to modify or repair the battery pack.
- Do not use the battery pack if it is damage or has been modified.
- Under abusive conditions, such as overheating, overcharging or physical damage, the battery pack may leak liquid. Avoid eye contact with the liquid as it may cause irritation or burn. Rinse with water if contact occurs and seek medical help promptly.
- Store the battery pack indoor at room temperature between  $-5^{\circ}$  and  $35^{\circ}$  for longer lasting battery life.
- Charge the battery at temperatures between  $10^{\circ}$  and  $45^{\circ}$ .
- Do not expose the battery pack to fire or high temperature to avoid explosion.

## Parts Installation

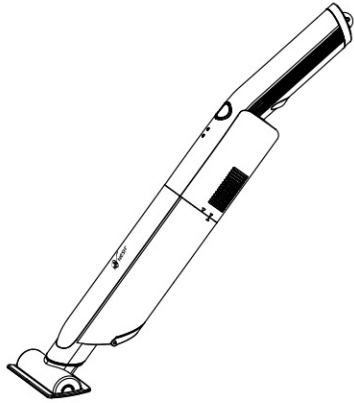

**A** Main Body + Soft Cleaning Tool



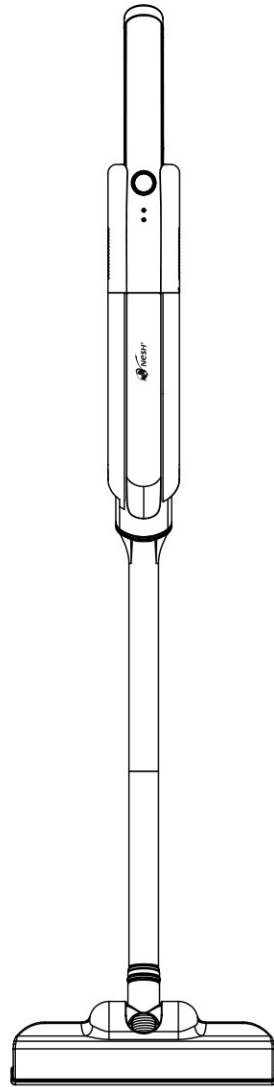

**B** Main Body + 2-in-1 Crevice Tool

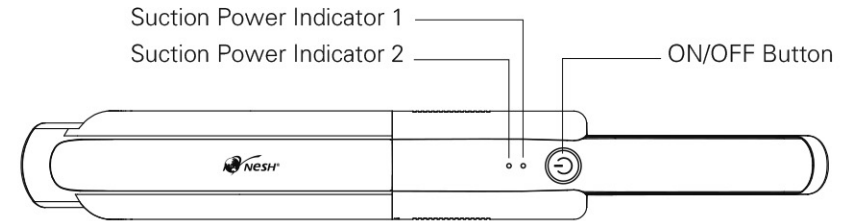

**C** Main Body + Floor Brush

## Product Usage



Indicators	Description
 ON/OFF Button	<ul style="list-style-type: none"> <li>• Press once to turn it on, Suction Power Indicator 1 will light up, indicating low-speed mode.</li> <li>• Press again to increase to high-speed mode, Suction Power Indicator 2 will also light up.</li> <li>• Press one more time to turn it off.</li> </ul>
	<b>Main Body Status</b>
	<ul style="list-style-type: none"> <li>• Discharging Status:                             <ul style="list-style-type: none"> <li>◦ Low Battery: Flashing red light quickly before auto shutdown</li> </ul> </li> <li>• Charging Status:                             <ul style="list-style-type: none"> <li>◦ Battery Level &lt; 60% : Flashing red light</li> <li>◦ Battery Level &gt; 60% : Flashing white light</li> <li>◦ Full Charge : Steady blue light</li> <li>◦ Detach Battery Pack : Flashing red light</li> </ul> </li> <li>• Filter Blockage Warning:                             <ul style="list-style-type: none"> <li>◦ Flashing red light for 5 times before auto shutdown</li> </ul> </li> </ul>
	<ul style="list-style-type: none"> <li>• Low-speed Mode : Suction Power Indicator 1 will light up.</li> <li>• High-speed Mode : Suction Power Indicator 1 and Suction Power Indicator 2 will light up.</li> </ul>
 Suction Power Indicators	<ul style="list-style-type: none"> <li>• Low-speed Mode : Suction Power Indicator 1 will light up.</li> <li>• High-speed Mode : Suction Power Indicator 1 and Suction Power Indicator 2 will light up.</li> </ul>

- NOTE:**
1. The product will shutdown automatically when the battery level is low during operation.
  2. In high-speed mode, if the battery level falls below 12%, the product will gradually switch to the low-speed mode.
  3. If battery level is between 0% and 20%, the product can only operate in low-speed mode.

## Product Usage

### Battery Pack Charging

The product can be charged in 2 ways. For optimal performance, it is recommended to fully charge the battery for the first time to ensure the best runtime and efficiency.

#### A Direct Charging on Main Body

Connect the USB-C cable to the charging port on the main body. There is no need to remove the battery pack, making the process quick and convenient.

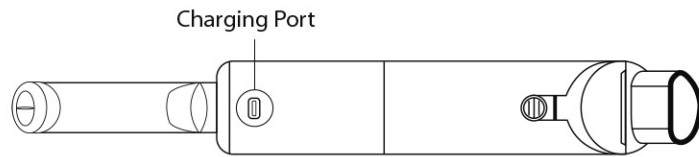

Back of Main Body

Battery Level < 60% : Flashing red light on ON/OFF button  
Battery Level > 60% : Flashing white light on ON/OFF button  
Fully Charged : Blue light on ON/OFF button

#### B Direct Charging on Battery Pack

The battery pack is equipped with a charging port for direct charging. You may purchase spare battery packs for use.

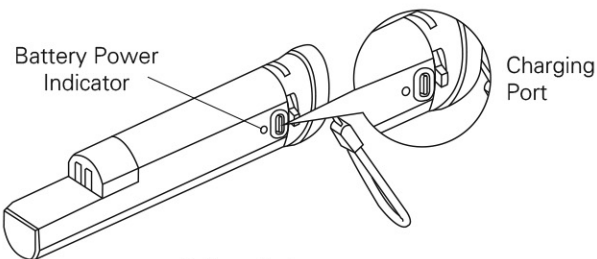

Battery Pack

Charging : Battery Power Indicator shows red  
Fully Charged : Battery Power Indicator shows green

## Cleaning & Maintenance

To maintain optimal cleaning performance, clean the filters after 4-6 vacuumings. Make sure Dust Box, filters and connected parts are in place before each use. Both Filter Box and HEPA filter need to be completely dry before use.

### Cleaning Dust Box

Please clean the Dust Box promptly to ensure optimal performance.

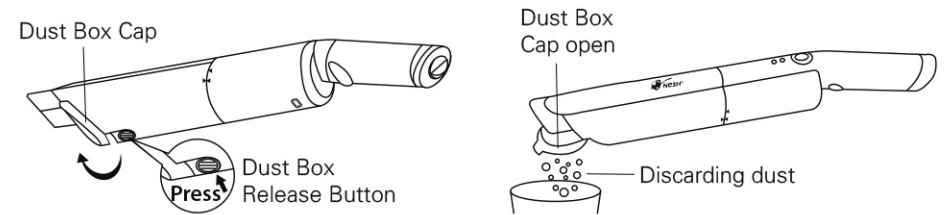

1. **Power Off:** Turn off the product.
2. **Align Dust Box Cap:** Position the Dust Box Cap over a garbage bin.
3. **Empty Dust Box:** Press the Dust Box Release Button to automatically open the cap. Then gently shake the Dust Box to discard the dust.
4. **Secure Dust Box Cap:** After emptying, close the Dust Box Cap by pressing the cap lock lightly until hear a “click” sound, indicating it is securely locked.

### Filter Cleaning

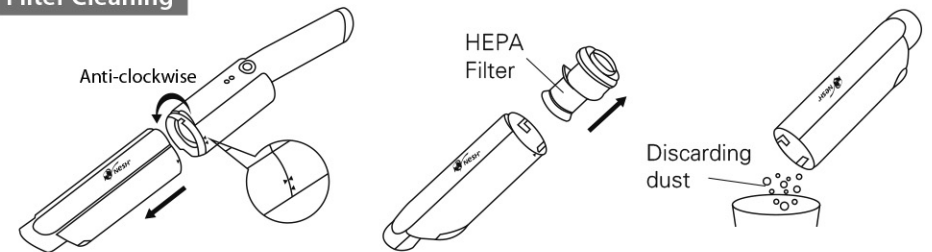

1. **Power Off:** Turn off the product.
2. **Remove Dust Box:** Twist anti-clockwise to detach the Dust Box from the main body.
3. **Detach Filter Box:** Twist clockwise then pull out the Filter Box from the Dust Box.
4. **Empty Dust Box:** Discard the dust in the garbage bin.
5. **Filter Dust Removal:** Gently knock off any dust from the HEPA filter.
6. **Rinsing (if necessary):** Only rinse with water if necessary.
7. **Drying:** Allow the filter to dry completely before reinstalling it back.

## Troubleshooting

Conditions	Possible Cause	Solution
ON/OFF Button flashes red light	Filter Box and HEPA filter are clogged	Clean Filter Box and HEPA filter
Motor is not working	Motor temperature protection is activated	Pull out the battery pack and let it cool to room temperature for 20 minutes
Cannot power on	Battery pack temperature is too high, temperature protection is activated	Pull out the battery pack and let it cool to room temperature for 20 minutes

Should you need further assistance:



Scan the QR code for more guidance



Alternatively, contact our NESH CARE Team  
**03-8060 3668**

## Limited Warranty

1. NESH Marketing Sdn. Bhd. warrants that this NESH product and/or its genuine NESH part/accessory is free from defects in material and workmanship at the time of its original purchase by a consumer.
2. If during the warranty period, this product fails to operate under normal use and service due to defects in design, materials and workmanship, NESH authorised distributors or service partners will at their option, either repair or replace the product in accordance with the terms and conditions stipulated herein.
3. NESH and its service partners reserve the right to charge a handling fee if a returned product is found not to be under warranty according to the conditions below.

### Terms & Conditions

1. This warranty is valid for the original proof of purchase issued to the original purchaser for this product by a NESH Authorised dealer. NESH reserves the right to refuse warranty service if this information has been removed or changed after the original purchase of the product from the dealer.
2. This warranty does not cover any failure of the product due to normal wear and tear, or due to misuse, including but not limited to use in other than the normal and customary manner, in accordance with the NESH instructions for use and maintenance of the product, nor does this warranty cover any failure of the product due to accident, hardware modification or adjustment, acts of God or damage resulting from shock and impact.
3. This warranty does not cover product failures caused by installations, modifications, repair or opening of the product performed by non-NESH Authorised personnel.
4. This warranty does not cover product failures which have been caused by use of accessories or other peripheral devices which are not NESH or NESH branded original accessories intended for use with the product.
5. There are no expressed warranties, whether in written or oral, other than this printed limited warranty.



**NESH MARKETING SDN BHD**

(199301002028)

12, Jalan Puteri 4/2, Bandar Puteri, 47100 Puchong, Selangor, Malaysia.

Tel: 03-8060 3668

E-mail: [info@nesh.com.my](mailto:info@nesh.com.my) Website: [www.nesh.com.my](http://www.nesh.com.my)

Facebook: NESH Malaysia Instagram: neshmalaysia



# HeroVac

## 使用说明书

Model: VC2025

使用之前，请仔细阅读此使用说明书以完全了解正确的使用方法。请保留此说明书以供日后参考。

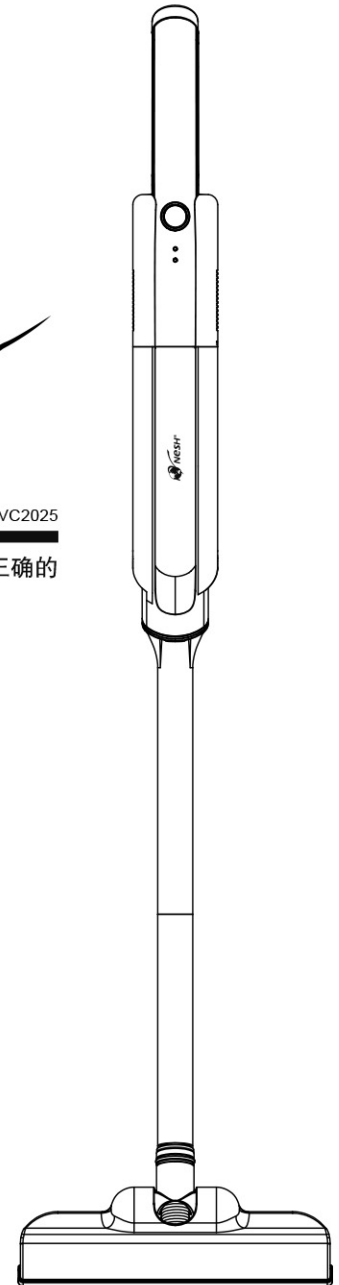

# 目录

敬爱的NESH用户:

感谢您选择我们的产品。请在操作和使用之前仔细阅读这本手册，以安全有效地使用此产品。请把使用说明书妥善保存以供日后参考；如果要把本机送给他人，请附上说明书。愿您喜欢我们的产品。

产品规格	.....01
产品结构	.....02
安全须知	.....04
部件安装	.....05
使用说明	.....06
清洁与保养	.....08
故障处理	.....09
保用声明	.....10
条例	.....10

### 特别声明

这份资料的所有内容都经过认真核对。如有印刷上、解读上的任何错误和遗漏，本公司将保留解释的权利。此外，任何技术改进将在修订本里通知。为了不断改进产品，我们保留对其做技术、程序以及外观改进的权利。

### 产品规格

型号	: VC2025
重量	: 1.8kg
额定电压	: 11.1V
额定功率	: 90W
电池容量	: 2500mAh

# 产品结构

## 产品功能简介

这是一款适用于全屋清洁的多功能无线吸尘器，可通过一键操作轻松转换为轻便的手持吸尘器，您甚至可以将其用作便携式车载吸尘器。

- 时尚&节省空间的设计
- 无刷马达提供高效吸力
- 双重过滤系统配备HEPA滤网
- 旋风技术
- 可拆卸电池组
- 强劲双档吸力

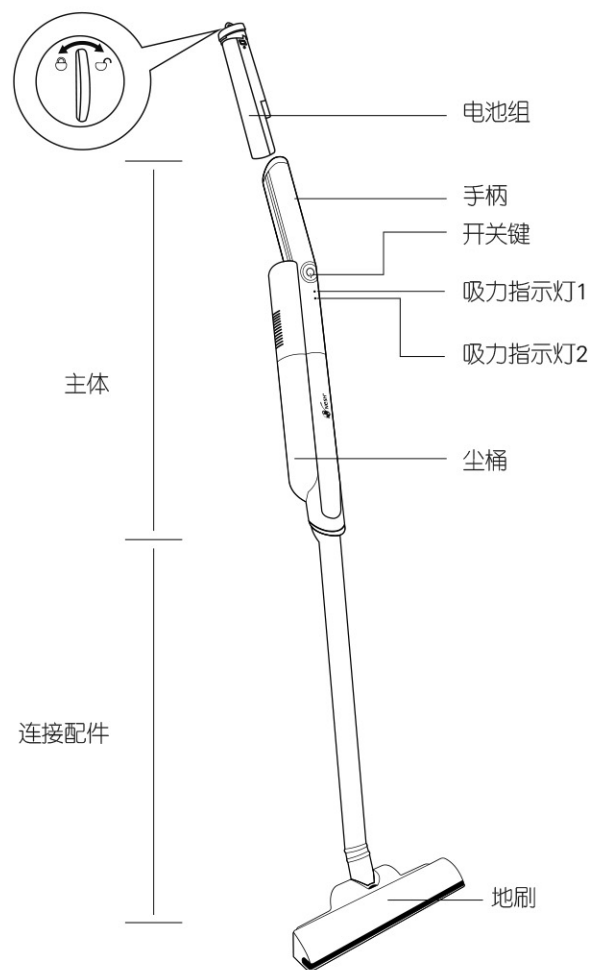

## 产品结构

### 包装清单

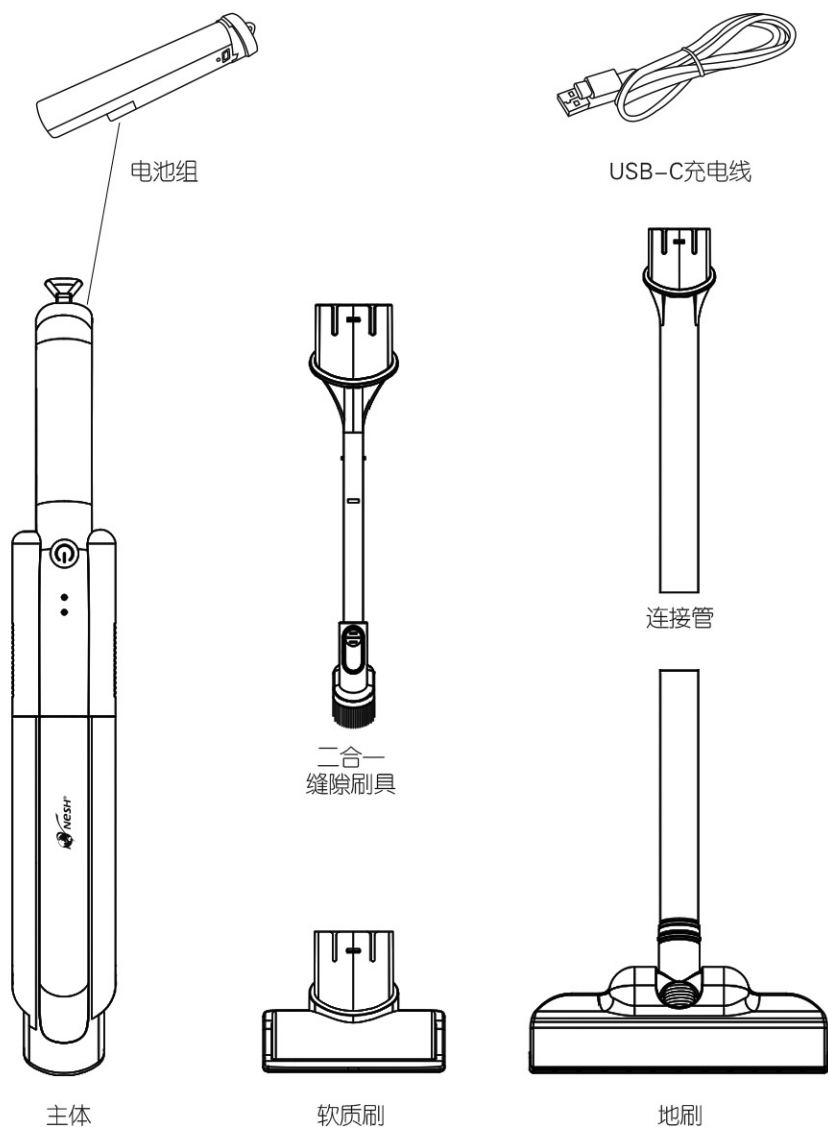

本说明书图示仅供参考，实际外观以实物为准。

## 安全须知

- 每次使用前检查所有部件是否损坏。如果损坏，停止使用。
- 只使用厂家部件更换。
- 请勿将本机用于手册中描述以外的任何用途。
- 避免将任何部件（滤网和尘桶除外）放在水或液体中。
- 为确保安全，请将产品放置在儿童无法触及的地方。
- 残障人士需在监督和指导下使用该产品。
- 在连接或断开任何电流之前，请始终关闭该装置。
- 请勿用湿手操作插头或装置。
- 使用前，请确保尘桶、滤网和连接部件已安装到位。
- 不要在任何堵塞的情况下使用产品；保持洞口没有灰尘、棉绒、头发和其他异物。
- 如果产品气流受阻，请勿使用。
- 为确保安全，使用时请避免吸力部件接触身体或松散的衣物。
- 如果装置出现故障、损坏或浸入水中，请勿使用。
- 在打扫楼梯时要格外小心。
- 请勿在产品开机状态下离开。
- 在地毯吸尘时，请避免在同一位置长时间停留，以免损坏地毯纤维。
- 不要将产品放置在不稳定的表面上，如椅子或桌子。
- 在插拔USB-C电线或电池组前，请先关闭产品。
- 在进行任何调整、清洁、维护或故障排除前，请先关闭产品。
- 使用前，请确保滤网完全晾干，以防损坏。
- 请勿自行改装或修理产品。
- 操作前，请确保产品处于常温。

### 电池组

电池组是产品的电源，请小心处理并遵循使用说明。

- 为防止意外，携带前请确保产品已关闭。切勿在按住开关键的情况下携带产品。
- 请将电池远离金属物体，以防止电池端子短路。
- 请勿自行改装或修理电池组。
- 若电池组损坏或已被改装，请勿使用。
- 在非常状态下，如过热、过度充电或物理损坏，电池组可能会有液体泄漏。避免液体接触眼睛而引起刺激或烧伤。若接触到液体，请用水冲洗并立即寻求医疗帮助。
- 将电池组存放在室内，温度范围为-5°C至35°C，以延长电池使用寿命。
- 仅在10°C至45°C的温度范围内为电池充电。
- 请勿将电池暴露在火源或高温环境中，以避免发生爆炸。

## 部件安装

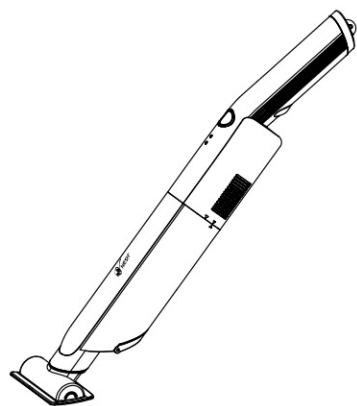

**A** 主体 + 软质刷

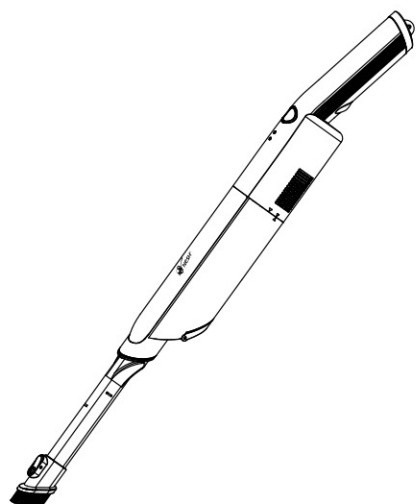

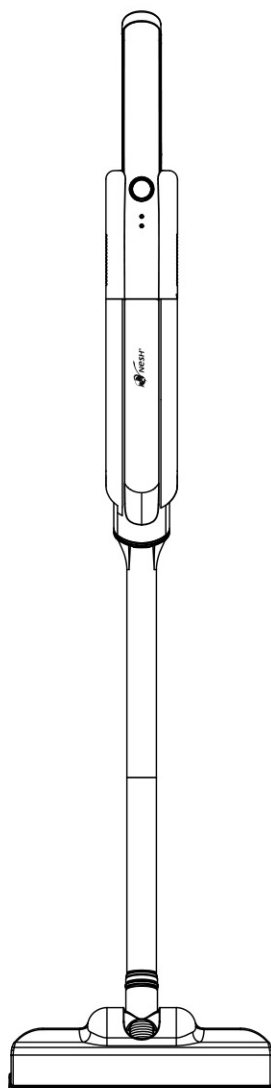

**B** 主体 + 二合一缝隙刷具



**C** 主体 + 地刷

## 使用说明



图标	描述
 开关键	<ul style="list-style-type: none"> <li>按一次为开机，吸力指示灯1将亮起，表示低速模式</li> <li>再按一次切换到高速模式，吸力指示灯2也会亮起</li> <li>再按一次即可关闭产品</li> </ul>
	<b>主机状态</b>
	<ul style="list-style-type: none"> <li>主机无充电状态：                             <ul style="list-style-type: none"> <li>电量低：红灯快速闪烁后熄灭</li> </ul> </li> <li>主机充电状态：                             <ul style="list-style-type: none"> <li>电量 &lt; 60%：红灯闪烁</li> <li>电量 &gt; 60%：白灯闪烁</li> <li>充电完成：蓝灯常亮</li> <li>拆卸电池组：红灯闪烁</li> </ul> </li> <li>滤网堵塞警告：                             <ul style="list-style-type: none"> <li>开关键闪烁红灯5次后自动关机</li> </ul> </li> </ul>
	<ul style="list-style-type: none"> <li>滤网堵塞警告：                             <ul style="list-style-type: none"> <li>开关键闪烁红灯5次后自动关机</li> </ul> </li> </ul>
 吸力指示灯	<ul style="list-style-type: none"> <li>低速模式：吸力指示灯1亮起</li> <li>高速模式：吸力指示灯2亮起</li> </ul>

- 注意：**
- 当产品在运行中电量过低时，会自动关机。
  - 在高速模式下，若电量低于12%，产品将自动切换至低速模式。
  - 当电量落在0%至20%之间时，产品只能以低速模式运行。

# 使用说明

## 产品充电

您可以通过两种方式给吸尘器充电。为了获得最佳性能，我们建议首次使用吸尘器前将电池组充满。这能确保设备达到最佳的运行时间和效率。

### A 主机直接充电

将USB-C充电线连接到主机上的充电端口。无需拆卸电池组，操作快速便捷。



主体背面

电量 < 60% : 开关键闪烁红灯  
电量 > 60% : 开关键闪烁白灯  
充电完成 : 开关键常亮蓝灯

### B 电池组充电

电池组配有充电端口，可以直接进行充电。您可以购买备用电池组以备使用。

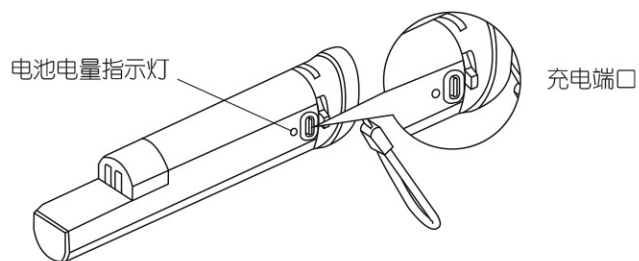

电池组

充电中 : 电池电量指示灯亮红色  
充电完成 : 电池电量指示灯亮绿色。

# 清洁与保养

为了保持最佳清洁性能，使用产品4-6次后，请清洁滤网。使用前，请确保尘桶、滤网和连接部件已正确安装到位。滤网盒和HEPA滤网在使用前请确保完全干燥。

## 清洁尘桶

请及时清洁尘桶以确保最佳性能。

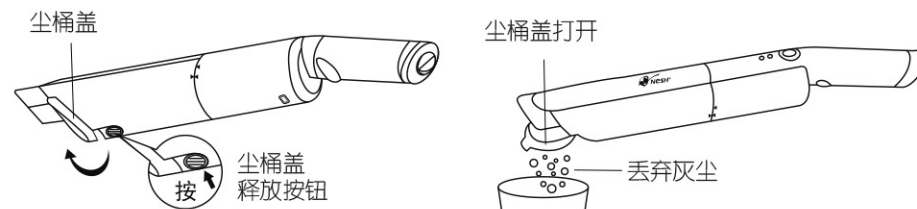

1. 关闭电源 : 关闭产品电源
2. 对准尘桶盖 : 将尘桶盖对准垃圾桶
3. 清空尘桶 : 按下尘桶盖释放按钮，盖子将自动打开。然后轻轻摇晃尘桶，丢弃灰尘
4. 固定尘桶盖 : 清空后，将盖子关上并轻压，直到听到“咔嗒”一声，表示盖子已安全锁紧

## 清洁滤网

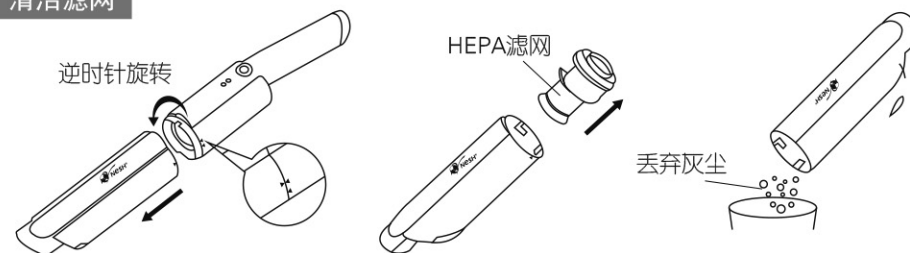

1. 关闭电源 : 关闭产品电源
2. 取下尘桶 : 逆时针旋转以将尘桶从主机上拆下
3. 拆卸滤网盒 : 顺时针旋转并拉出滤网盒
4. 清空尘桶 : 将尘桶中的灰尘丢入垃圾桶
5. 滤网除尘 : 轻轻拍打HEPA滤网以去除灰尘
6. 冲洗 (如有必要) : 仅在必要时用水冲洗
7. 晾干 : 在重新安装前，请确保滤网完全干燥

## 故障处理

故障现象	可能产生的原因	解决方法
开关键闪烁红灯	尘桶和HEPA滤网阻塞	清洁尘桶和HEPA滤网
主机无法开启	电机温度保护	将电池组取出，并放置20分钟使其降至室温
电源无法打开	温度保护模式已启动，因电池组温度过高	将电池组取出，并放置20分钟使其降至室温

如果您需要进一步的帮助：



请扫描以上二维码  
查看更多资讯



欢迎联系我们的  
NESH CARE 客服团队  
**03-8060 3668**

## 保用声明

1. Nesh Marketing Sdn. Bhd. 保证顾客所购买的产品/配件/零件品质皆完好无缺。
2. 如本产品于保用期内因品质问题而无法操作，NESH授权经销商或服务伙伴将根据以下条例，选择维修或更换产品。
3. 如产品不符合以下条例，NESH授权经销商或服务伙伴将有权征收服务费。

### 条例

1. 此产品保证是由NESH授权经销商提供并有效于原购者。NESH有权保留 / 拒绝提供保用服务，如购买者无法出示购买证明。
2. 根据NESH产品的说明书，此保用并不包括人为，误用，意外，修改，天灾等所造成的损坏。
3. 此项保用并不包括非授权人士因安装，修改，维修或处理产品时所造成之损坏。
4. 此项保用并不包括因使用非NESH品牌配件或零件所造成的损坏。
5. 除有效保证印本，其他货品质量保证，无论书写或口述皆无效。